

1		
Description	Material	Finish
Body	Brass	Nickel
Socket	BE CU	Gold
Insulation	Teflon	Teflon
Washer	PH Bronze	Gold
Gasket	SI Rubber	Rubber
Crimp Ring	Brass	Nickel
Insulator	Teflon	Teflon

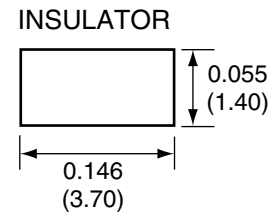

RECOMMENDED CABLE STRIPPING DIMENSIONS

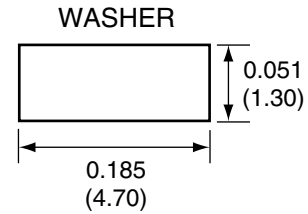
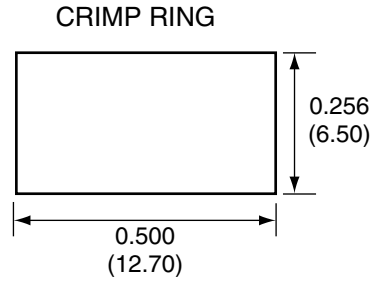
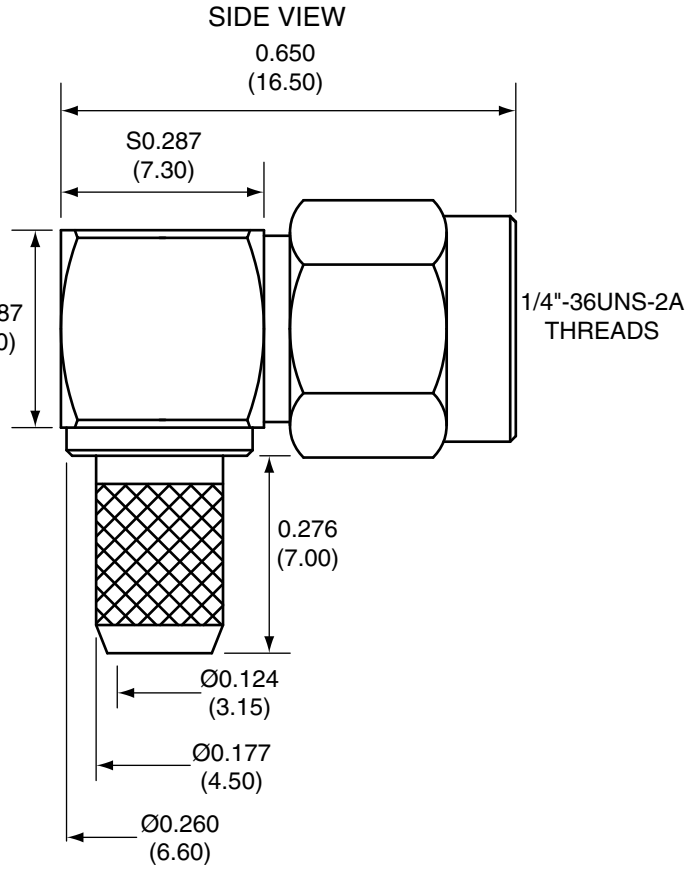
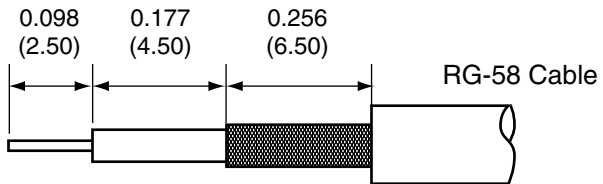

Title **RP-SMA MALE RIGHT ANGLE
CABLE END CRIMP FOR RG58 CABLE**

Part No. **CONREV SMA012-R58**

Revision: **1.0**

Dimensions: **INCHES (mm)**

Date: **6/1/2006**

CONNECTOR CITY
159 ORT LANE
MERLIN, OR 97532
PH (541)-471-6256
FAX (541)-471-6251

Sheet 1 of 1

CONNECTOR CITY
THE VALUE OF CONNECTIONS